



[CLICK for More Info Online](#)

Subframe Connector System for Classic Mustang, Cougar and Falcon



APPLICATIONS

Comet	1960-65	Hardtops only
Cougar	1967-70	All models
Falcon	1960-65	Hardtops only
Mustang	1964-70	All models
Ranchero	1960-65	All models



- Weld-in frame connectors
- Bolt-in center support
- Fits Dual 3" Exhaust

- Increases chassis rigidity
- Improves vehicle handling



Subframe Connector System

Total Control Products subframe connector systems create a direct structural bridge between the front suspension subframe and rear subframe at the forward leaf-spring mount. A noticeable improvement in chassis rigidity yields more responsive handling and sharper acceleration while relying less on the flexible sheet metal for chassis stiffness. The system is comprised of weld-in tubular subframe connectors, removable center support and adjustable driveshaft safety loop (most models). Each subframe connector fits tightly against the undercarriage without the requirement of notching or cutting into the floor structure. Adding the bolt-in center connector support creates triangulation across the undercarriage with enough room below the transmission tunnel to carefully run 3" exhaust. Available for purchase as a complete package or in stages.

Hardtop Connector Packages

Includes weld-in subframe connectors, bolt-in center support, adjustable driveshaft safety loop and Grade 8 mounting hardware.



HARDTOP PACKAGES		
Comet	1960-65	TCP PKG-SFC-53
Cougar	1967-70	TCP PKG-SFC-51
Falcon	1960-65	TCP PKG-SFC-53
Mustang	1964-70	TCP PKG-SFC-51
Ranchero	1960-65	TCP PKG-SFC-53

Convertible Connector Packages

Includes weld-in subframe connectors, bolt-in center support and Grade 8 mounting hardware. *Driveshaft safety loop is not available for convertible vehicle model.*



CONVERTIBLE PACKAGES		
Cougar	1967-70	TCP PKG-SFC-52
Mustang	1964-70	TCP PKG-SFC-52

Purchase In Stages

The subframe connector system can be broken down into separate stages and purchased separately.

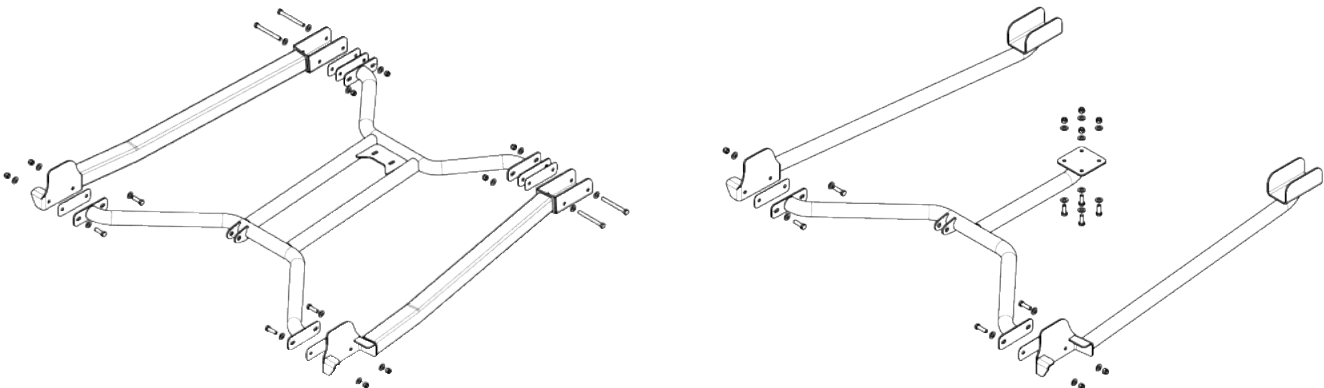

Subframe Connectors (Weld-In)

Our weld-in subframe connectors are available for both hardtop and convertible models. Hardtop connectors are constructed from 2 x 2 x .083" wall boxed tubing with a single mandrel bend to tightly follow the contour of the undercarriage and to better visually blend with the factory subframes. 1-5/8 x .134" wall round tubing is used for the convertible connectors to achieve maximum ground clearance below

the lower reinforcement pans. The ends of each connector are completely sealed by the 7 gauge formed sheet metal mounts. Both front and rear mounts extend to the height of their respective attachment points to place the securing weld at the strongest point of the factory subframe. Mounting holes are predrilled for simple installation of our available connector supports.



Hardtop Connectors

- Connects front subframe to rear frame rail forward of leaf-spring mount
- 2 x 2 x .083" tubing



HARDTOP CONNECTORS		
Comet	1960-65	TCP SUBFC-03
Cougar	1967-70	TCP SUBFC-01
Falcon	1960-65	TCP SUBFC-03
Mustang	1964-70	TCP SUBFC-01
Ranchero	1960-65	TCP SUBFC-03

Convertible Connectors

1-5/8 x .134" tubing



CONVERTIBLE CONNECTORS		
Cougar	1967-70	TCP SUBFC-02
Mustang	1964-70	TCP SUBFC-02

The Perfect Fit

Center Support - To make allowance for variations between vehicles, shims are used in mounting the center support.

Driveshaft Safety Loop - Slotted holes and a reversible mounting bracket enable adjustment for height and fore/aft position.

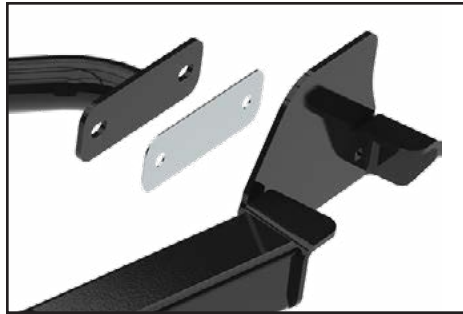
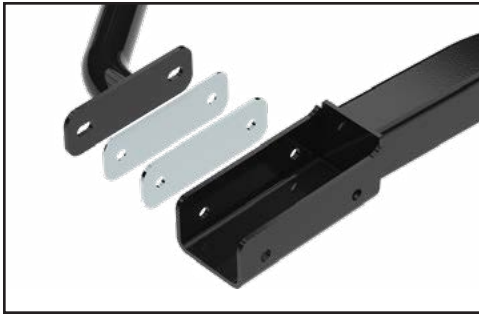

Hardtop Center Support

Bolt-in center support remains easily removable for access to drivetrain. Features integrated mounts for driveshaft safety loop and rear suspension torque arm. Includes Grade 8 mounting hardware. Requires weld-in subframe connectors for installation.

- 1-5/8 x .134" wall round tubing
- Sits 1-1/2" below OE front subframe
- Allows room for dual exhaust

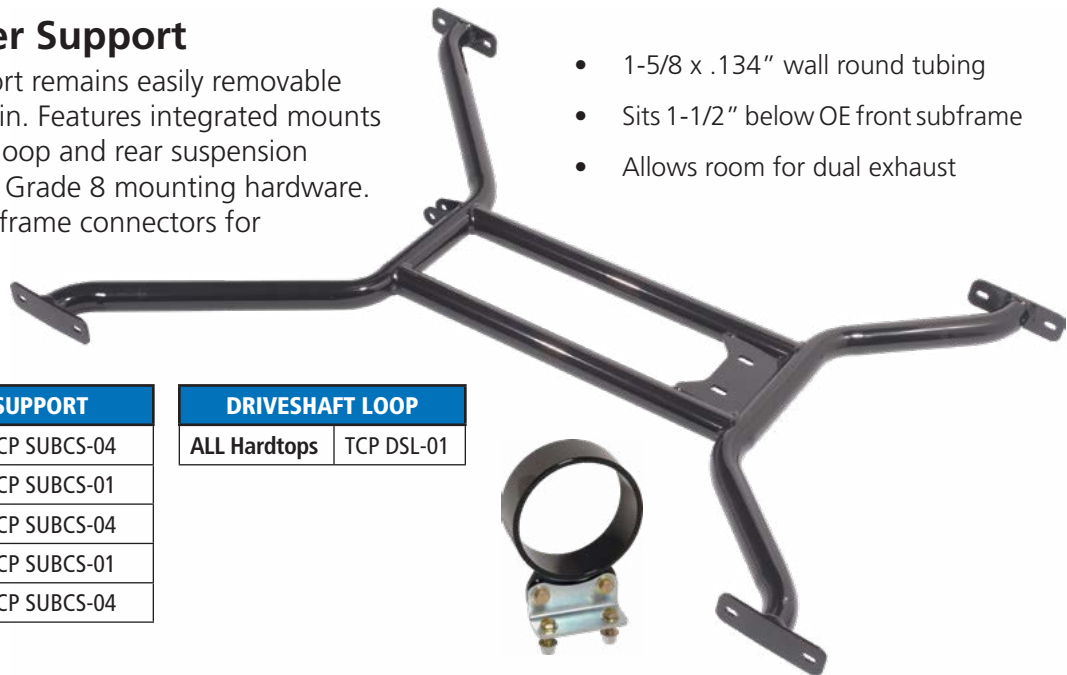

HARDTOP CENTER SUPPORT		
Comet	1960-65	TCP SUBCS-04
Cougar	1967-70	TCP SUBCS-01
Falcon	1960-65	TCP SUBCS-04
Mustang	1964-70	TCP SUBCS-01
Ranchero	1960-65	TCP SUBCS-04

DRIVESHAFT LOOP	
ALL Hardtops	TCP DSL-01

Convertible Center Support

Removable bolt-in convertible center support mounts to the rearward end of the weld-in subframe connectors and to the steel plate that spans between the seat pan reinforcement boxes. Features integrated mount for rear suspension torque arm. Includes Grade 8 mounting hardware.

- 1-5/8 x .134" tubing
- Mounts to seat pan brace

CONVERTIBLE CENTER SUPPORT		
Cougar	1967-70	TCP SUBCS-03
Mustang	1964-70	TCP SUBCS-03

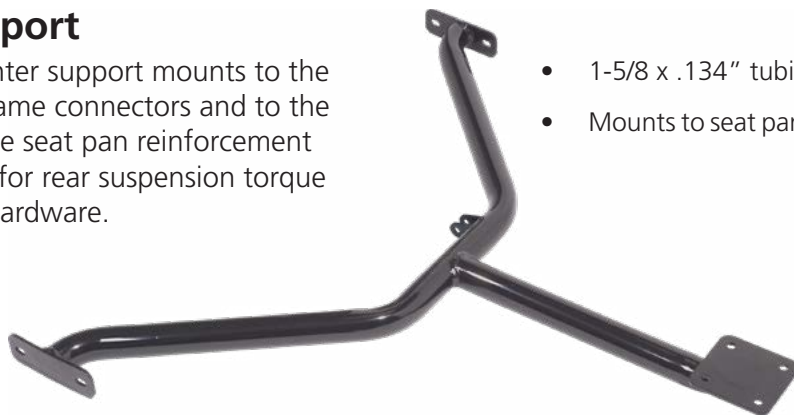

All prices subject to change. Current pricing available at www.totalcontrolproducts.com.



Total Control Products
8661 Younger Creek Drive – Sacramento, CA 95828
A Chris Alston's Chassisworks, Inc., Brand

Order: 800-722-2269
Tech: 916-388-0288
Fax: 916-388-0295

tcpsales@cachassisworks.com
tcpstech@cachassisworks.com
www.totalcontrolproducts.com