

DESCRIPTION	PERIMETER-X 4 x 2 FRAME, 36" LADDER BAR	
Chris Alston's CHASSISWORKS INC. 8661 YOUNGER CREEK DRIVE SACRAMENTO, CA 95828 (916) 388-0288 FAX 388-0295	PART NO.	7765-U01
	6/4/18	DWG: 7951-7765U01

1	1	5762	FRONT SUSPENSION, STREET MACHINE
2	2	4563	4 x 2 A-ARM SHORT RAIL 6" GROUND CLEARANCE
3	2	4558	ROCKER SUPPORT TUBE, 2 x 4 A-ARM FRAME
4	2	4561-108	V-TUBE, 108 WHEELBASE, X-BRACE, PERIMETER CHASSIS
5	1	7725-U01	4 x 2 REAR FRAME, 36 INCH LADDER BAR, NO EXHAUST PORT
6	1	4516	BEND 180° 2 x 1
7	2	7972-5001	TUBE CAP, 1 x 2 x 12 GA (.100)
8	2	7972-5011	ASSY, CENTER GUSSET, PERIMETER FRAME
9	4	D60.125-24.000	TUBE, EXHAUST PORT, \varnothing 3 3/4 x .125 WALL DOM, 24.00 LONG
10	1	7972-5012	BUMPER MOUNT, DRIVER, PERIMETER FRAME
11	1	7972-5013	BUMPER MOUNT, PASSENGER, PERIMETER FRAME
12	2	B3224.120-30.00	TUBE, 3 x 2 x .120 WALL ERW x 30.00 LONG
13	1	7972-2608	ENGINE FRAME ADAPTER, DRV, UNIVERSAL 36 CROSSMEMBER
14	1	7972-2609	ENGINE FRAME ADAPTER, PSGR, UNIVERSAL 36 CROSSMEMBER

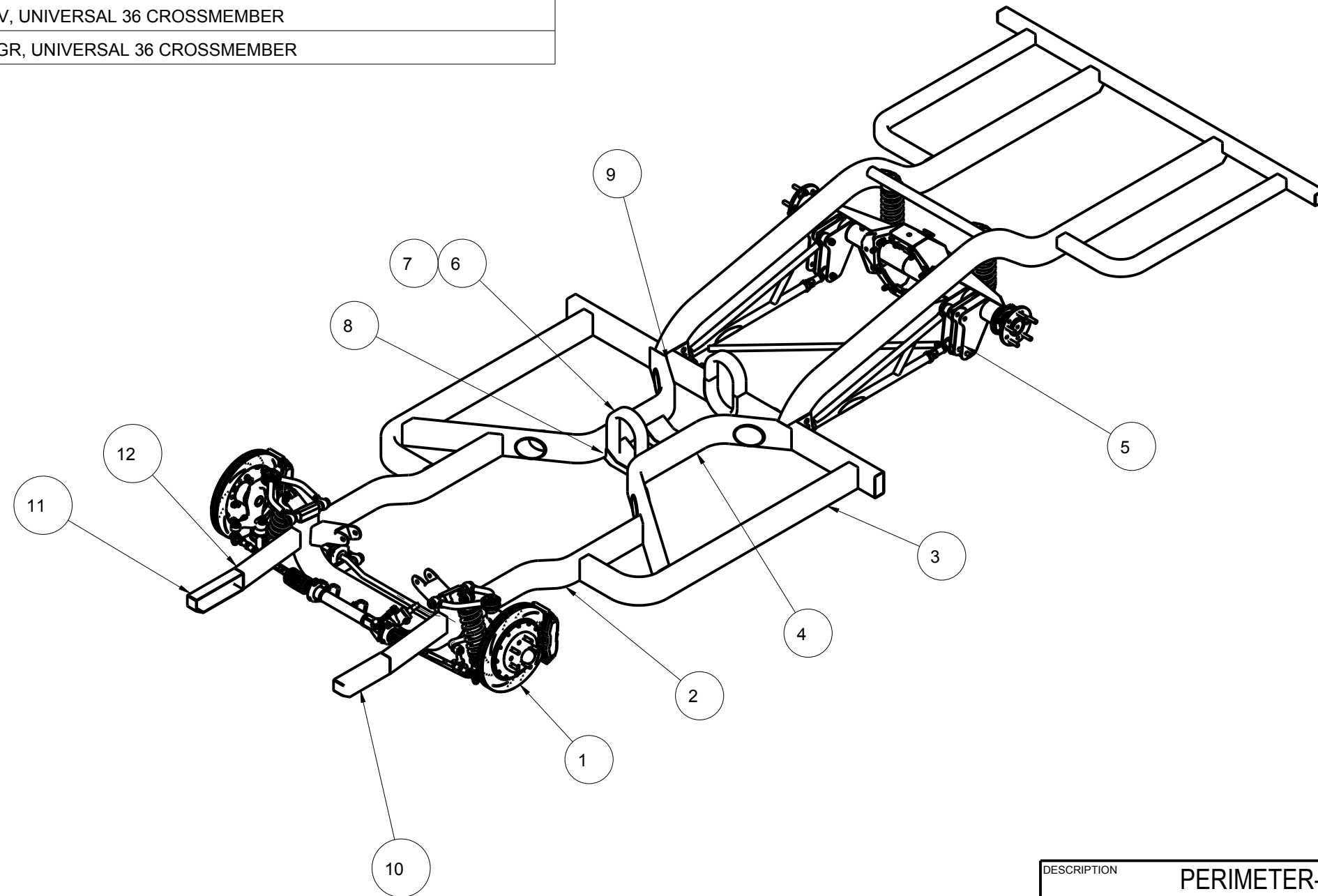

DESCRIPTION	PERIMETER-X 4 x 2 FRAME, 36" LADDER BAR	
Chris Alston's CHASSISWORKS INC. 8661 YOUNGER CREEK DRIVE SACRAMENTO, CA 95828 (916) 388-0288 FAX 388-0295	PART NO.	7765-U01
	6/4/18	DWG: 7951-7765U01