

**Ford 9" Assembled Ultra Case Third Member Packages with 40-Spline Spool**



**Ultra Case 40-Spline Spool Package**

(450 hp & up, spool only)

The Ultra Case package is a completely assembled Ford 9" third member shipped ready to install. The heavy-duty aluminum 9" Ultra Case is engineered to provide better lubrication to the pinion bearings and incorporates a uniquely designed pinion support that connects with the case to provide superior ring-and-pinion life. Four chrome-moly studs are encapsulated by billet caps, allowing for shorter and stronger studs. The tail bearing is larger than factory, allowing it to withstand greater rpm speeds, and is secured by a special retainer plate. Third members are equipped with 40-spline spools. Ring and pinion sets are manufactured from high-nickel 9310 steel to endure the high-impact shock loads of drag racing. Gear ratio selections include: 3.40, 3.50, 3.60, 3.70, 3.89, 4.11, 4.29, 4.57, 4.71, and 4.86.

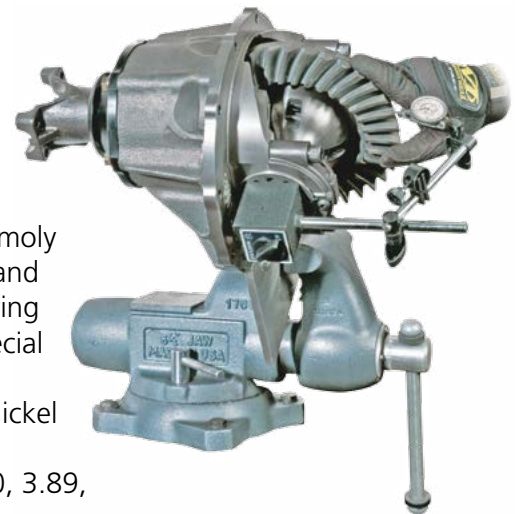

8520-968	<b>Ultra Case (aluminum), 40-spline Spool, 9310 gear set with choice of ratio (3.40-4.86), chrome-moly 1350 yoke, large-stem iron pinion support</b>
----------	--

## Spool

### Full-Size Steel Spool (40-spline) - STRIP ONLY

Spools provide drag-racing applications the ultimate component for strength and simplicity. Machined from forced chrome-moly to ensure the most stable ring-gear mount. This is a drag-race-only component and not suitable for street use.



## Pinion Yoke

### Chrome-moly (35-spline)

Chrome-moly yokes offer greater strength and reduced deflection for high-torque applications such as drag racing. The chrome-moly yoke can be used with both small- and large-stem pinion gears.



## Ring & Pinion Gear Sets

### Drag Competition Gear Sets

The Drag Competition gear set is manufactured from high-nickel 9310 steel. The selected gear material better absorbs the high-impact shock loads that occur at the professional level of drag racing. Not suitable for street or road-racing use due to shortened service life of more ductile gear teeth. Available in stronger (large stem) 35-spline pinion drive.



Available Gear Ratios									
3.40	3.50	3.60	3.70	3.89	4.11	4.29	4.57	4.71	4.86

All prices subject to change. Current pricing available at [www.cachassisworks.com](http://www.cachassisworks.com).



Chris Alston's Chassisworks, Inc.  
8661 Younger Creek Drive  
Sacramento, CA 95828

Order: 800-722-2269  
Tech: 916-388-0288  
Fax: 916-388-0295

[sales@cachassisworks.com](mailto:sales@cachassisworks.com)  
[www.cachassisworks.com](http://www.cachassisworks.com)